

# CONTAINER/CART DUMPERS

## And "Trainable" Steel Containers/Carts

*Marathon's Cart/Container Dumpers can extend the benefits of compaction to all areas of your operation while keeping equipment investments to a minimum.*

**M**arathon's standard Cart/Container Dumpers are designed to handle 2 and 4 cubic yard "trainable" steel containers or 1 cubic yard plastic tilt carts. Using a towing vehicle to "train" the carts from various locations throughout a facility to the dumper locations reduces labor to a fraction of that required to perform the same job manually.



### Ground Level Dumpers...

Ground Level Dumpers are used to dump containers at ground level into your stationary or self-contained compactor. They help extend the benefits of compaction to all areas of your operation, while keeping your equipment investment to a minimum. They are ideal for park systems, shopping malls and large or multi-building plants.

### Dock Level Dumpers...

Dock Level Dumpers are used to dump containers that are rolled directly onto a stationary compactor from a loading dock self-contained units next to a dock. They are ideal for industrial plants where waste accumulates in many locations. Standard units are powered by a separate 3 hp, 3 gpm power pack with electric controls. Heavy duty units are powered by a 10 hp, 10 gpm power pack with electric controls. Electric controls gives complete control to the operator at any stage of dumping.

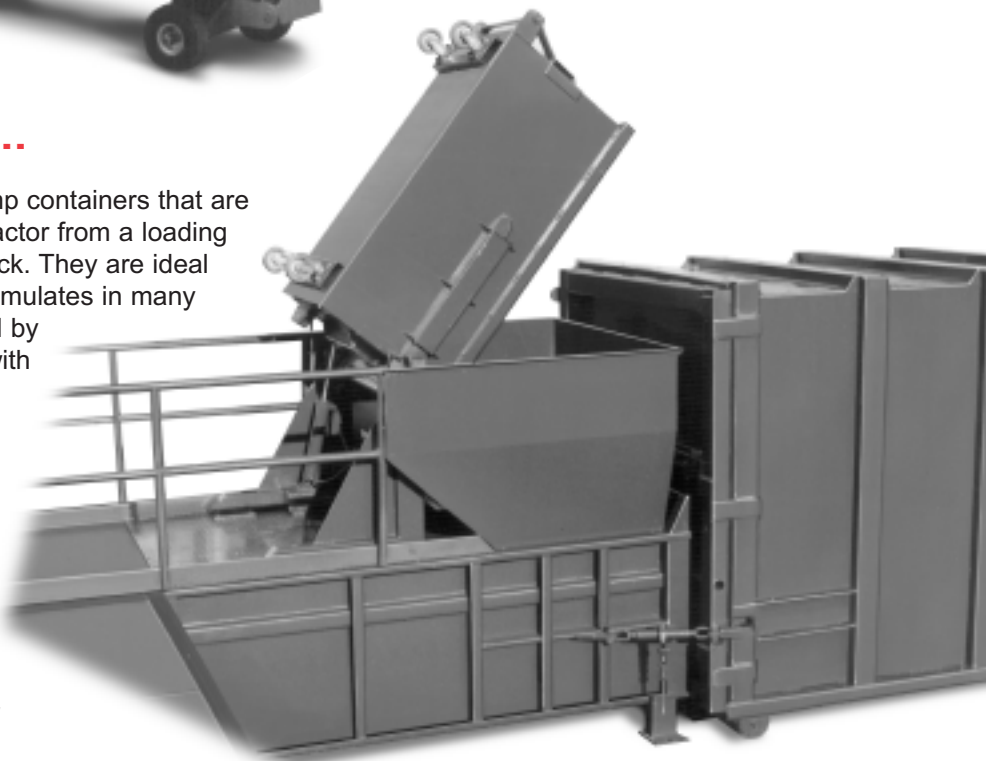

***Marathon's Cart Dumpers are available in Heavy Duty models that can handle gross loads up to 5000 pounds.***

# Cart/Container Dumpers

## In Action...

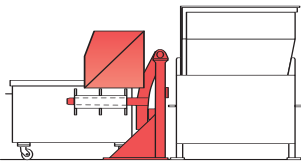

Container is rolled into dumper arms. Marathon's 3 or 10 hp. power pack is activated from outside the area of operation.

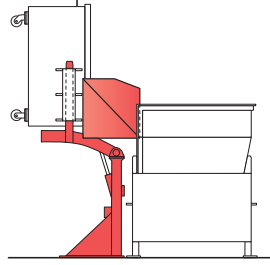

Special guards prevent spillage or leakage even in the vertical position. Operator has full control of cycle at all times.

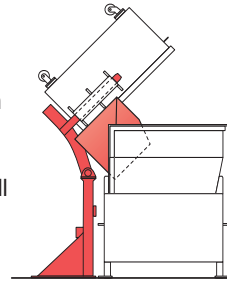

Container is tilted a full 45 degrees past vertical, assuring complete cleanout. Dumping cycle is 26 seconds for the heavy duty and 36 seconds for standard models.

## Fork Style Dumper

Marathon's Cart/Container Dumpers are available in standard or heavy duty models. Heavy duty cart dumpers are designed to handle gross loads up to 5,000 lbs.



## Tilt Truck Dumper

The Tilt Truck type dumpers handle molded plastic tilt trucks. They are designed to hold the tilt truck during dumping without mechanical locks to maintain.

## In-plant Trainable Containers

Marathon offers 2 and 4 cubic yard capacity cart/containers ruggedly designed for in-plant use. They come standard with polyurethane-tired casters.



*Trainable Container Options Include: 1,600 lbs. polyurethane-tired casters; sleeves for interchangeable use with front loaders; tow bars for "trainable" containers (trains can be towed by forklift or similar unit).*

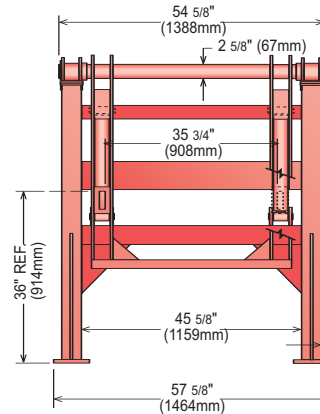
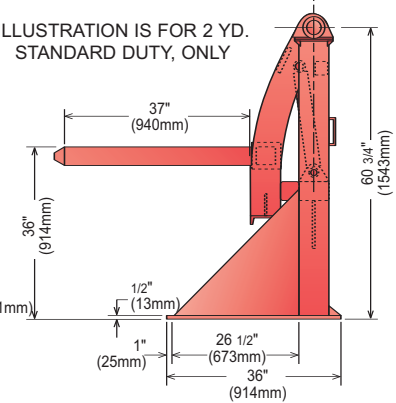

ILLUSTRATION IS FOR 2 YD. STANDARD DUTY, ONLY



## Specifications

### Standard

### Heavy Duty

	Standard	Heavy Duty
Cylinders (2)		
Bore	3" (76mm)	4 1/2" 114mm
Rod	1 1/4" (32mm)	2 1/2" (64mm)
Stroke	16" (406mm)	25" (635mm)
Hydraulic Pressure	2000 psi. (138 bar)	1350 psi. (93 bar)
Hydraulic Pump Capacity	3 gpm (11.4L/m)	10 gpm (37.9 L/m)
Motor Size	3 hp (2.2 kW)	10 hp (7.5 kW)
Controls	Electrical	Electrical
Cycle Time	36 sec.	35 sec.
Weight Capacity	up to 2500 lbs.(1134kg)	up to 5000 lbs.(2268.kg)
Tilt Cart Weight Capacity	up to 2000 lbs.(907kg)	up to 4500 lbs.(2041kg)

## Custom Engineered Dumpers

For applications with pre-existing or non-standard carts/containers, Marathon can design a custom dumper to meet your specifications and conform to all applicable ANSI Safety Standards.

## Other Marathon Dumpers

**Integral Dumper** for Self-Contained Compactors (RJ-250SC) Fork or Tilt Cart type available.

**Cart Flipper** for Stationary, Self-Contained, and Pak'nainers Compactors to dump 90 and 96 gallon containers.

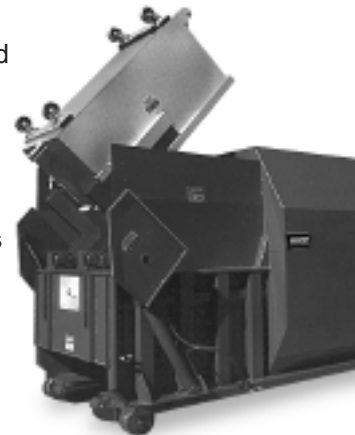

MARATHON EQUIPMENT COMPANY

P.O. Box 1798 • Vernon, AL 35592-1798 USA • (205) 695-9105 fax (205) 695-7250 1-800-633-8974

130 Hwy. 339 • Yerington, NV 89447 USA • (775) 463-4030 fax (775) 463-4531 1-800-624-5724

1102 Industrial Park Rd. • Clearfield, PA 16830 USA • (814) 765-0200 fax (814) 765-2072 1-800-922-7062

Visit our web site: [www.MarathonEquipment.com](http://www.MarathonEquipment.com)

Pictures in this literature are illustrative only. Specifications are subject to change without notice in order to accommodate improvements to the equipment. Certified in compliance with ANSI Regulation Z245.2, all OSHA standards, and certified under WASTEC's Stationary Compactor Certification Program. Products must be used with safe practice and in accordance with said regulations and standards.

