

# Heavy-Duty Vertical Balers



Marathon Heavy-Duty Vertical Balers are full of features designed for ease of operation and maintenance.

- ▼ Automatic feed gate for hands-free loading
- ▼ Side-mounted power unit for easy access and maintenance
- ▼ Redundant interlock system
- ▼ Easy to use chain ejector
- ▼ Programmable "smart" relay control system
- ▼ Front facing push button control panel
- ▼ Quiet running submerged 10 HP motor and gear pump



## Available Options:



Wire Guides & Auto Eject



Bale Made Light



Lockable Disconnect





# Recycler Vertical Baler...

## Easy to Use - Maintenance Friendly



*Shown with optional bale made light, wire guides, automatic ejector and electrical disconnect.*

**Marathon High Density Vertical Balers** feature many innovations for ease of use and maintenance friendly access. Features such as the side-mounted power unit with submerged motor and pump, front facing panel box, redundant feed gate interlock system, all add up to a reliable baler for years of trouble-free recycling. The Smart Relay adds safety features, easy set-up, and diagnostic capabilities to

your baler. The motor and pump are submerged in the hydraulic fluid tank which offers much quieter operation.

Your baler can also be equipped with optional features that add even more efficiency and ease of use: Automatic bale ejector that activates when the door is opened; Wire Guides eliminate the need to go behind the baler for a complete front tie-off system; a Bale Made Light illuminates when a bale is made to notify the operator when it is time to eject the bale; an optional lockable electrical disconnect can be added for local Lock-Out/Tag-Out.

*Front opening control panel eliminates the need for 48" side clearance as required by NEC standards.*



*Programmable "smart" relay adds diagnostic and trouble-shooting capabilities*



*Fixed retainer teeth on the door and rear of the baler to reduce material springback.*



# Loaded with Features & Benefits

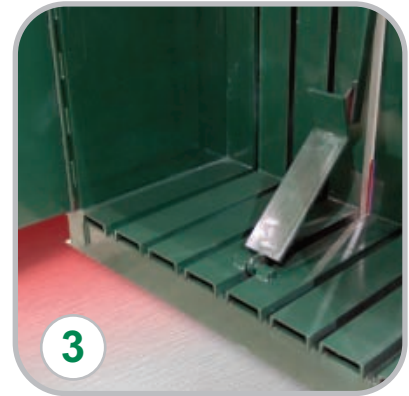
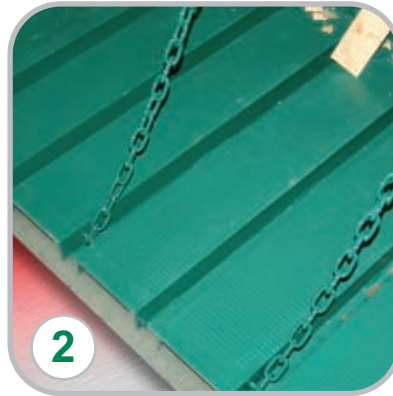

1. Redundant interlock system that works with the gate latch for added safety redundancy.
2. The standard chain bale ejector is manually set after the bale door is opened.
3. The optional automatic bale ejector is also available. It is actuated when the bale door is opened.

4. Automatic feed gate that opens at the end of each cycle as the platen is retracted for "hands free" loading.
5. Platen features replaceable wear pads and cast iron shoe guides.
6. Standard controls: Keylock On/Off Auto Cycle switch, Emergency Stop button, and Platen Raise/Lower switch. A baler ready light indicates the baler is operational.
7. The panel box features a programmable "smart" relay control system which disables the baler if an attempt to override the interlocks is made.
8. The side-mounted, self-contained power unit is convenient for maintenance and servicing. The pump with 10 HP motor is submerged in the hydraulic oil tank for quiet and efficient running operation while producing 56,550 lbs. of force.

# Specifications

## V-6030 HD

## V-7230 HD

### Performance Data:

Cylinder Bore, Rod & Stroke	6" x 3.5" x 48"	6" x 3.5" x 48"
Pump Flow (gear pump)	10.5 GPM	10.5 GPM
Motor	10 HP	10 HP
(1750 RPM)	(1750 RPM)	
System Pressure	2,000 PSI	2,000 PSI
Max. System Pressure	2200 PSI	2200 PSI
Platen Force	56,550 Lbs	56,550 Lbs
Platen Pressure	34 PSI	29 PSI
Cycle Time	58 Seconds	58 Seconds

### Electrical Specs (same all models):

Control Voltage:	120 VAC
Electrical:	208/230/460 3-Phase
Control Box:	NEMA 4 UL Listed Box & Controls
Controls:	OFF/ON Security Key Switch; 3 Position Selector Switch; EMERGENCY STOP Button; IEC Motor Starter and Overload, Programmable Smart Relay

### Dimensional Data:

<b>A</b> Overall Width	89 1/4"	103"
<b>B</b> Overall Depth	41 1/2"	44 1/2"
<b>C</b> Overall Depth (w/optional wire guides)	54 1/2"	57 1/2"
<b>D</b> Overall Height	140"	142"
<b>E</b> Feed Height	48 1/4"	50 1/2"
<b>F</b> Feed Opening Width	60"	72"
<b>G</b> Feed Opening Height	25"	25"
<b>H</b> Bale Door Clearance	58"	70"

### Bale Size Data:

Bale Size	60"W x 30"D x 48"H	72"W x 30"D x 48"H
Bale Volume	50 cu.ft.	60 cu.ft.
Bale Weight (OCC)	Up to 1,100 Lbs	Up to 1,400 Lbs
No. Bale Ties (14 ga. x 14ft. long):	6	6
<b>Total Baler Weight:</b>	4,200 Lbs	5,600 Lbs

### Structural Data:

- Body Side Plates:** 7 Ga.
- Body Floor:** 7 Ga. floor plate, 6" structural channel
- Floor Structure:** 6" structural channel (8" on V-7230)
- Top Cylinder Supports:** Heavy 8" structural channel integrated into main frame of 10" structural channel and 1" x 12" plate beam
- Platen Face:** 1/4" plate, 6" structural channels and tubes
- Bale Door:** 7 ga. door plate, 4 x 3 structural tube top rail, 4" structural angle and channel
- Ejector:** Manually-engaged, chain type
- Paint:** Primer bottom coat; industrial grade top coat, low VOC, high solids

Available  
**GreenBuilt™**  
Options

- ▼ All-temperature biodegradable hydraulic fluid
- ▼ 5 HP energy efficient unit with submersible variable displacement pump

### Other Available Options

- Bale Made Light
- Electrical Disconnect Switch
- Oil Heater
- Wire Guides (for front bale tie-off)
- Automatic Bale Ejector
- Single Phase Power Unit

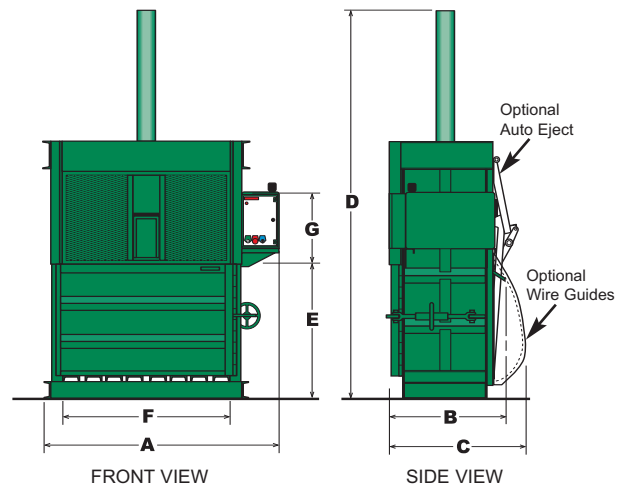

Visit our web site: [MarathonEquipment.com](http://MarathonEquipment.com)



MARATHON EQUIPMENT COMPANY

P.O. Box 1798 • Vernon, AL 35592-1798 USA • (205) 695-9105 fax (205) 695-7250 1-800-633-8974

130 Hwy. 339 • Yerington, NV 89447 USA • (775) 463-4030 fax (775) 463-4531 1-800-624-5724

1102 Industrial Park Rd. • Clearfield, PA 16830 USA • (814) 765-0200 fax (814) 765-2072 1-800-922-7062

Pictures in this literature are illustrative only. Specifications are subject to change without notice in order to accommodate improvements to the equipment. Certified in compliance with ANSI Regulation Z245.5 and all OSHA standards. Products must be used with safe practice and in accordance with said regulations and standards.

